

INFRA RED WIRELESS SYSTEM

User's Guide

IRR-30 / IRR-15 Receiver IRH-15c / IRB-10c / IRN-10 Transmitter
IRD-10/IRD-30/IRD-60 Sensors

Due to constant improvements, specifications are subject to change without a prior notice.

AZDEN CORPORATION

1-12-17 Kamirenjaku Mitaka-shi Tokyo 181-8533 Japan
Tel :+81(0)422-55-5115 Fax :+81(0)422-55-0131
E-mail : sales@azden.co.jp URL <http://www.azden.co.jp>

Printed in Japan 080905-2



Index

Page	Subject
2	Important Safety Instructions
3	Handling care for Ni-MH battery
4	Introduction
5	Feature
6	System configuration, Installation case beside Plasma Display Monitor
7	IRR-30 Receiver set up
8	IRR-15 Receiver set up
9	IRB-10c Transmitter
10	IRN-10 Transmitter
11	IRH-15c Handheld Microphone
12	IRD-10/20/60 External Sensor
13	Trouble shooting
13	Microphone suggestions, Regulation
14	Specification

Important Safety Instructions

1. Read these instructions for use.
2. Keep these instructions in a safe place.
3. Heed all warnings.
4. Follow all instructions.
5. Do not use near water.
6. Clean only with a dry cloth.
7. Do not block any ventilation openings. Install in accordance with the manufacturer's instructions.
8. Do not install near any heat sources such as central heating radiators, electric heaters, stoves, or other units that produce heat (e.g. amplifiers).
9. Only use attachments/accessories specified by the manufacturer.
10. Use only with the cart, stand, tripod, bracket, or table specified by the manufacturer, or sold with the unit. When a cart is used, use caution when moving the cart/unit combination to avoid injury from tip-over.
11. Unplug during lightning storms or when unused for long periods of time.
12. Refer all servicing to qualified service personnel. Servicing is required if the unit has been damaged in any way, such as mains cable or plug damage, liquid has been spilled, objects have fallen inside, the unit has been exposed to rain or moisture, does not operate properly or has been dropped.

Specification

IRR-15/IRR-30 Receiver

Sub-carrier Frequency	2.06MHz&2.56MHz	IRR-15: 1CH IRR-30:2CH
Type	Super Heterodyne-Crystal Controlled	
Modulation	FM	
S/N Ratio	More than 90dB	
Reception Sensitivity	More than 25dB μ V	
Audio Output Adjustment	Mic:-20dB maxLine: 0dB max	
Audio Output Impedance	Mic:Less than 1.5k Ω Line: Less than 1k Ω	
Power Requirement	12V DC 350mA	
Size	100(W) x 161(D) x 44(H)mm (IRR-15)	
	215(W) x 210(D) x 44(H)mm (IRR-30)	
Weight	530g (IRR-15)	
	1.15kg(IRR-30)	

IRH-15c

Sub-carrier Frequency	2.06MHz&2.56MHz Switchable	
Modulation	FM	
Microphone Element Type	Uni Directional Dynamic	
Battery Type	2-"AA" Alkaline (1.5V x 2)	
	2-"AA" rechargeable Ni-MH or Ni-Cd(1.2 x 2)	
Battery Life	>8hours w/alkaline batteries -low power mode	
	>5hours w/alkaline batteries -high power mode	
Size	240 x 58mm	
Weight	300g w/alkaline batteries	

IRB-10c

Sub-carrier Frequency	2.06MHz&2.56MHz Switchable	
Modulation	FM	
Microphone Element Type	Electret Condenser	
Frequency Response	50-10kHz \pm 3dB	
Battery Type	2-"AA" Alkaline (1.5V x 2)	
	2-"AA" rechargeable Ni-MH or Ni-Cd(1.2 x 2)	
Battery Life	>10hours w/alkaline batteries -low power mode	
	>8hours w/alkaline batteries -high power mode	
Size	100(H) x 64(W) x 27(D)mm	
Weight	140g w/alkaline batteries	

IRN-10

Sub-carrier frequencies	2.06MHz or 2.56MHz	
Modulation	FM	
Microphone element type	Uni-directional electret x 2	
Frequency response	50-9kHz \pm 3dB	
Ext Mic Input Jack	3.5mm	
Battery type	2-"AA" Alkaline (1.5V x 2)	
	2-"AA" rechargeable Ni-MH or Ni-Cd(1.2 x 2)	
Battery life	>10hours w/alkaline batteries- low power mode	
	>8hours w/alkaline batteries- high power mode	
Size	80(H)x70(W)x27(D)mm	
Weight	120g- Transmitter w/alkaline batteries	
	62g Transmitter w/o alkaline batteries	

IRD-10/30/IRD-60

Output	F-Connector(IRD-30/60) / RCA-Connector(IRD-10)	
Power	Powered by reciever (24V 10mA)	
Size	52(W)x27(H)x73(D)mm (IRD-10)	
	72.5(W) x 27(H) x 50(D)mm (IRD-30)	
	100 x 30mm (IRD-60)	
Weight	210g Included 10m cable and bracket(IRD-10)	
	90g Included mounting bracket (IRD-30)	
	170g Include mounting bracket (IRD-60)	

Microphone Suggestions

In addition to the attached uni-directional microphone, any one of many fine external microphones can be used. In the case of head or collar worn mics is that it would be possible to increase the gain (volume) without adding feedback noise. This is due to the proximity of the mic element to the speaker's mouth. Any of the following Azden microphones will produce excellent results.

- EX-503 Omni-directional Lavalier
- EX-505U Uni-directional Lavalier
- HS-12 Behind head version of HS-11
- HS-11 Uni-directional Headset
- HS-9 Omni-directional Headset
- CM-20D Uni-directional Collar-worn

Regulation

CE Declaration of Conformity

This equipment is in compliance with the essential requirements and other relevant provisions of Directives 89/336/EC or 73/23/EC.

Before putting the equipment into operation, please observe the respective country-specific regulations!

FCC Rules

This equipment has been tested and found to comply with the limits for of the FCC Rules. These limits are designed to provide reasonable protection against harmful interference in a residential installation. This equipment generates, uses and can radiate radio frequency energy and, if not installed and used in accordance with the instructions, may cause harmful interference to radio communications.

However, there is no guarantee that interference will not occur in a particular installation. If this equipment does cause harmful interference to radio or television reception, which can be determined by turning the equipment off and on, the user is encouraged to try to correct the interference by one or more of the following measures:

- 1) Reorient or relocate the receiving antenna.
- 2) Increase the separation between the equipment and receiver.
- 3) Connect the equipment into an outlet on a circuit different from that to which the receiver is connected.
- 4) Consult the dealer or an experienced radio/TV technician for help. The users manual or instruction manual for an intentional or unintentional radiator shall caution the user that changes or modifications not expressly

Maintenance and Care

Do not attempt to service this unit yourself as opening or removing covers may expose dangerous voltage or other hazards. Refer all servicing to qualified service personnel.

Clean only with a dry cloth. Do not use detergents or other liquids.

Replacement parts

When replacement parts are required, be sure the service technician uses replacement parts specified by the manufacturer or those that have the same characteristics as the original part. Unauthorized substitutions may result in fire, electric shock, or other hazards.

Safety check

Upon completion of any service or repairs to this unit, ask the service technician to perform safety checks to determine that the product is in proper operating condition.

Handling Care for Ni-MH battery

- 1 To prevent the battery break, carefully ready this manual.
- 2 The operation environment of battery is $-20^{\circ}\text{C}\sim +60^{\circ}\text{C}$. If the operation temperature is out of this range, the battery may damage.
- 3 Don't leave the battery inside of car under direct sunshine, don't face the battery for direct sunshine and don't keep the battery beside heater. Also, don't use the batter at very cold place, which is zero degree or less than zero.
Such environment may make short life and damage goods.
- 4 Don't put the battery in the slot water and watery.
- 5 Inside of battery, it includes the alkaline liquid. If the liquid touches to hands, skin etc., immediately washes them.

Prohibition:

Don't throw away the battery in the fire and don't make warm it.

Don't soldering it directly.

Minus and plus terminal, don't connect by needle, cable etc

Don't set the battery + - terminal in reverse.

Don't disassemble and assembly.

Don't throw away and put high pressure on it.

Recharging user only our accepted recharge.

Don't insert battery into car external battery socket, wall socket.

Don't user any other equipment without our permission.

Introduction

Thank you for selecting the Azden "RED" infrared system as your wireless solution. We are confident that it will perform beyond your expectations. For over 40 years Azden Corporation has been creating technologically advanced products. By taking advantage of the latest in CAD design and SMT production techniques, Azden's engineers are able to produce products that exceed the published specifications and perform well beyond the warranty period.

Azden "RED" represents a breakthrough in wireless. Instead of the normal radio waves that other wireless systems use, Azden "RED" uses invisible light beams in the infrared range.

Through the use of infrared you will no longer be plagued by outside interference. "RED's" enhanced performance assures you of the finest in audio clarity and reliability. The specially selected high-frequencies provide you with trouble free performance, even in fluorescently lit rooms. Like all infrared, Azden "RED" will not operate correctly outside in the sunlight.

In the real world, the ability to use multiple systems in the same location without frequency interference will prove to be a tremendous benefit to you. Using infrared means that the audio generated in your room stays in your room. Your discussions cannot be overheard on other systems in other rooms.

Designed by professionals - for professionals, Azden "RED" will provide you with years of worry-free, high-quality performance.

Charger

About AC/DC adapter

Use Azden recommending AC/DC adapter for recharging the battery on the transmitter unit.

BC-27 for IRR-15 / IRR-30

BC-29 for IRB-10c / IRN-10 / IRH-15c

Troubleshooting

The single most important thing to ALWAYS check when trouble arises is the battery. Make sure they are fresh and the POWER LED is glowing brightly.

SYMPTOM CAUSE

No POWER LED

- Receiver switch is set to "OFF"- change to "ON"
- External 12V DC power source is not connected or is malfunctioning
- Dead or very weak battery in body-pack or handheld

No audio from body-pack

- Make sure the volume on the receiver is turned up for the appropriate channel and the body-pack is powered ON
- If two body-packs are being used, make sure they are set to different frequency channels
- If using an external mic, make sure it is plugged in to the body-pack properly and the internal gain control has been adjusted.

No audio from handheld mic

- Make sure the volume on the receiver is turned up for the appropriate channel and the handheld mic is powered ON
- If two handheld mics are being used, make sure they are set to different frequency channels

Intermittent audio

- Make sure there is a clear path between the emitter and the receiving sensor. Best results are obtained when the receiving sensors are mounted high - above everyone's head Limited working range a. Install extra external sensors
- If using a body-pack, set the Power Mode to Hi.
- Make sure all emitting points on the transmitters are covered by hands, towel etc. Move them and face the emitting point to the receiver direction.
- Make sure all emitting points on the transmitters are wet. Make clean with dry towel.
- Make sure direct sun light or any strong light is coming into the sensor.
Be careful the mounting position of external sensor or the facing direction of internal sensor.

The IRD-10/30/60 External Sensor

To increase the working range of the system, up to three external sensors can be added. External sensors are powered by the receiver and can be plugged into the "EXT.SENSOR INPUTS" (9) on the rear panel. Plugging into inputs 1 and/or 2 (9) adds to the built-in front sensor (3) and extends the working range by 15m with IRD-10, 15m in straight direction with IRD-30 and 15m half-diameter range in 360 degree.

Plugging into input 3 (9) automatically disconnects the front panel sensor. This way, if the front panel sensor is blocked (perhaps in a secured cabinet or closet) it can be replaced.

Guide for sensor installation

IRD-10

Fix the installing bracket by screws firmly.

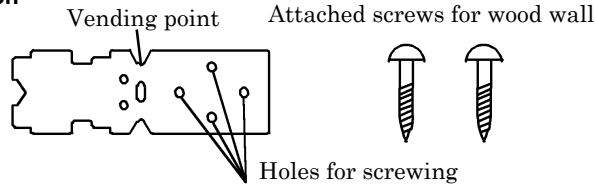

- 1, The black color side should face the near side when fixing the bracket. Vend the bracket 90 degree to front.
- 2, Fix screws
Screw pitch: 30mm and 24mm Black color side
- 3, Slide the sensor unit for hooking up to the bracket.
Adjusting the angle of the bracket for sliding the sensor much easily.

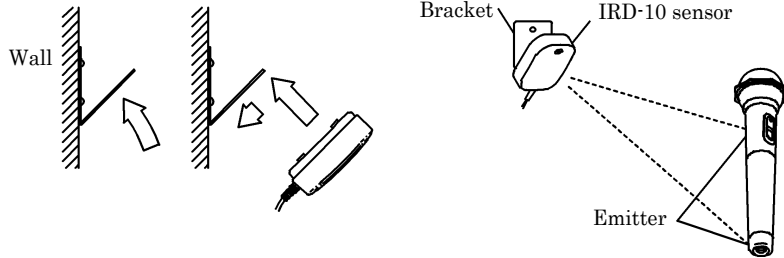

The microphone emitter and sensor top surface face vertically is best position. Adjust the angle for suitable angle.

IRD-30/IRD-60 Installation

IRD-30 Sensor covering area:

Up and down direction and both side, each 120 degree

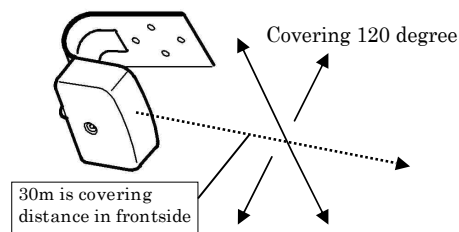

IRD-60 Sensor covering area

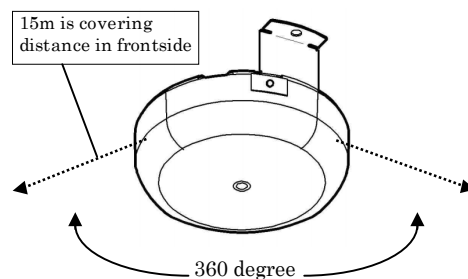

Connection cable is not attached as standard items. Buy coaxial cable 3C-2V or 5C-2V.

Feature

Receiver

- ◆ New circuit design for minimizing the interference with the Plasma display.
- ◆ New method for eliminating the strident noise.
- ◆ Don't get interference by other generally used wireless method like UHF and VHF. At the same location, even adjacent rooms, same package can be used without any interference.
- ◆ Internal sensor can cover an open area up to 144 square meter under transmitter high power mode and 108 square meter with Lo mode.
- ◆ Up to max. three external sensors can be extended depends on size of room. Three type sensors are available as option item.
- ◆ Azden Newly designed state-of-the-art Crystal Servo technology for frequency-stable transmitting

Sensor

- ◆ One is IRD-10, which can fly to 10m distance on the line of sight. IRD-30, which can cover up / down and right / left side 120 degree up to 15m in straight direction, and IRD-60 called "Dome sensor" can cover 360 degree area reception up to 15m half-diameter.

Microphone/Transmitter

- ◆ Three type of microphones, handheld, pendant and table top, are available depends on users' needs.
- ◆ Handheld microphone IRH-15c utilize two emitters at bottom and top for transmitting audio in all around 360 degree direction. Up to 20m distance in line of sight can fly constantly.
- ◆ High and low switch for selection of emitting power depends on the size of location and for extending the life of battery.
- ◆ Two channel setting on IRH-15c, IRB-10c and IRN-10 can be switched to either channel on the spot by just sliding switch.
- ◆ IRB-10c allow speakers for hands free action thanks to pendant or body clip wearing. Use IRN-10 if the speakers are installed on the ceiling by adjusting the mic gain.

System Configuration

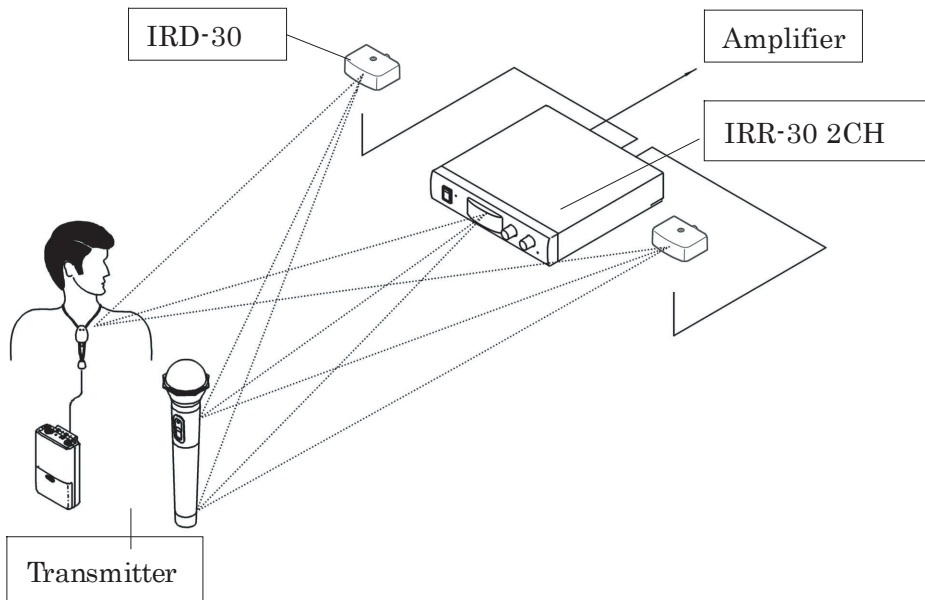

Installation case beside Plasma Display Monitor

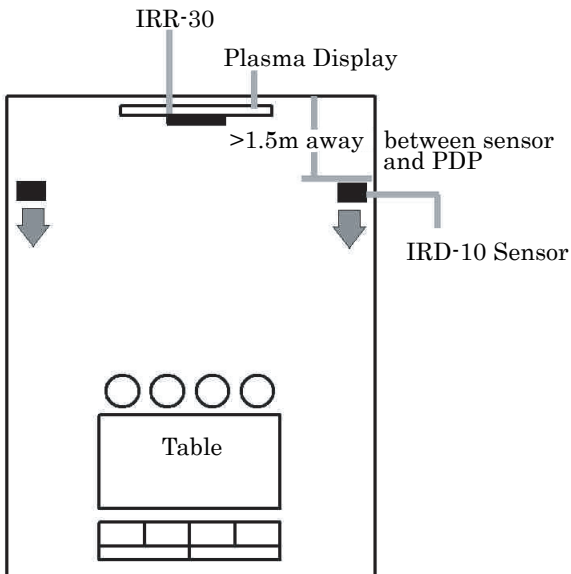

IRH-15c Handheld Microphone

Infrared handheld mic.: IRH-15c

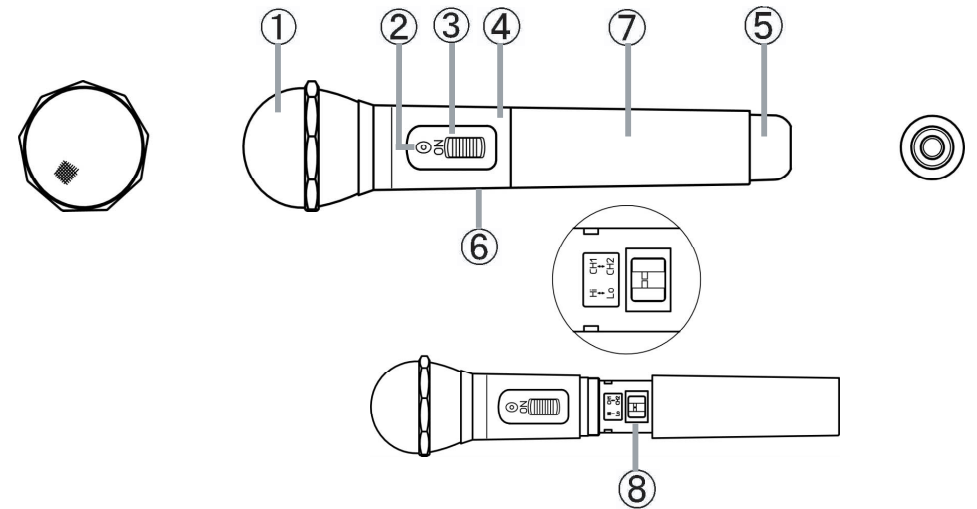

- 1, Microphone head
- 2, Power Indication LED
Green color is indicated when the power is on.
If it is red color, battery charging requires. Charge the batteries by AC/DC adapter(BC-29) or replacing with fresh 2-"AA" Alkarine batteries.
- 3, Power On switch
The mic. start working by sliding the switch to the ON position with proper frequency. About frequency setting refer clause 8.
- 4, Microphone case
- 5, Infra red emitting point
Audio is transmitted from this point. Don't cover this point by hands and any other materials.
- 6, Another Infra red emitting point
Also, don't cover this part. Hold the battery cover area when you are in operation.
- 7, Battery cover
2-"AA" rechargeable NI-MH battery is packed as standard item. Only the original NI-MH battery can be recharged with AC/DC adapter. 2-"AA" alkaline are our recommendation as dry battery.
- 8, Frequency Selection (CH1/CH2) and output power Hi/Lo
The IRH-15c can be set to transmit on either one of two preset frequencies. This is so that two different speakers can talk at the same time in the same room. Select the desired one by using ball-point pen.
Output power also can be changed Hi/Lo. If the distance between microphone and receiver is very near, set to Lo for saving battery life. At Lo position, the battery life is approx. 8 hours. (when using Azden original battery after full charging). At Hi position, the battery life is approx. 6 hours.

5. Using the IRB-10c:

After inserting fresh batteries, the IRB-10c can be powered by sliding the ON/OFF Switch (4) to the ON position. The Power LED will glow when the IRB-10c is powered ON as will the red LED on the front panel of the IRR-30 which corresponds to the chosen channel. Be sure to slide the Power Switch to OFF when not in use to preserve battery life. The Power LED on the mic will turn from green to red to indicate "Low Battery".

The emitter (1) must be plugged into the IRB-10c (3) and either attached to the clothing with the clip (2) or worn around the neck with the lanyard as described in section V. The emitter acts as the transmitter and, for best results, should be worn in such a way as to have a clear path to the receiving sensor(s).

The IRB-10c can be attached to the belt or other clothing by way of the metal belt clip. It is suggested that the body-pack be worn in the front portion of the body to avoid the possibility of damaging it.

6. Attaching and Using the Lanyard with the IRE-10 Emitter:

As described above, the emitter(1) can be attached to clothing using the built-in clip. To attach, insert the metal clip through the holes (2) on the lanyard's clear plastic slide.

IRN-10 Transmitter

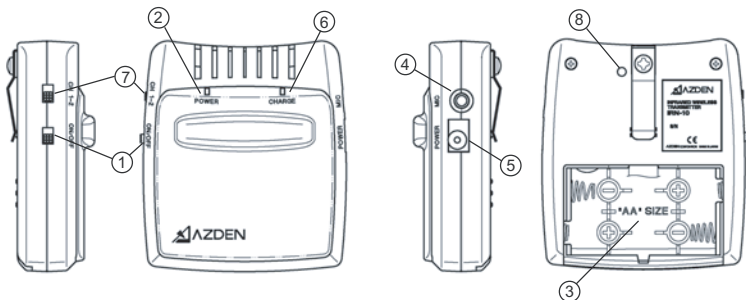

1. Power switch - turn ON/OFF the transmitter by sliding the switch.
2. Power LED - Glow GREEN when the transmitter is ON. Glow RED when the battery is low.
3. Battery door - When replacing the battery slide it down to open.
4. External Mic input jack - Plug the ext. mic into the jack, then internal mic will be disabled.
5. Power input - Plug the charger jack into the port.
6. Charge LED - Glow RED when when charging.
7. Channel switch - Slide the switch to select the frequency.
8. Mic gain adjustment point - Use very tiny Philip type screw driver for turning the inside screw. By turning the screw to the counterclockwise, the gain go up and down. Find the optimum gain by turning the screw while lessening the speech through a speaker. If howling appear, this phenomenon can be minimized by adjusting the internal microphone level through this feature. The best solution to avoid the howling is to use uni-directional microphone like our HS-11(headset mic),EX-505U (lavalier type) etc.

IRR-30 Receiver Set up

I. Receiver Front Panel:

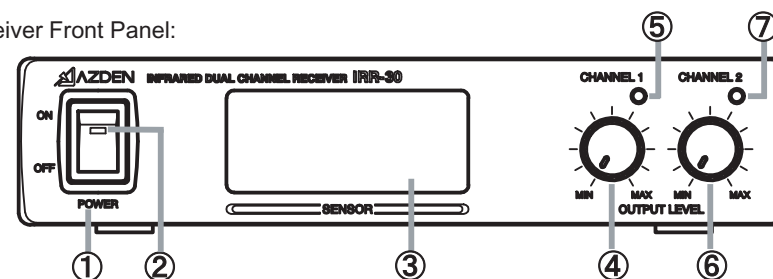

1. Power Switch - turns the receiver On and Off.
2. Power LED - indicates the power state of the receiver.
3. Receiving Sensors - internal receiving infrared sensors.
4. Channel 1 Volume - adjusts the output volume for Channel 1.
5. Channel 1 Indicator - glows green when connecting Channel 1.
6. Channel 2 Volume - adjusts the output volume for Channel 2.
7. Channel 2 Indicator - glows green when connecting Channel 2.

II. Receiver Rear Panel:

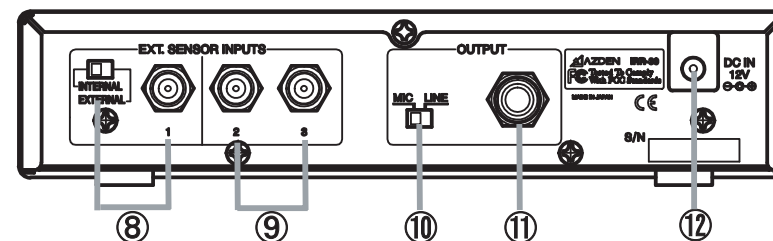

8. Switched External Sensor Input (F connector) - Plugging an external sensor in here turns the front panel sensor (3) off.
9. 2-External Sensor Inputs (F connector) - Plugging external sensors in here extends the receiver's potential working distance.
10. Input Selector - selects either Mic (-20dB max @ 1.5K ohms) or Line (+4dB max @ 1k ohms) level for the output jack (10).
11. Output Jack - connects the receiver to a mixer or audio amplifier/speaker combination (1/4 inch connector). In general, choose "MIC" when attaching to a mixer input and "LINE" when attaching to an amplifier input.
12. Power Input - plug in AC-DC adapter (BC-27) to power receiver (12VAC-1.6A) Don't use other one beside of our recommending.

III. Mounting the Receiver:

As infrared operates "line-of-sight" and can be interrupted by any solid object, it is strongly suggested that the receiver (or external sensors) be mounted or placed in a location that puts the receiving sensors above the audience's heads or any other obstacles.

IV. Powering the Receiver:

The IRR-30 is powered by a AC-DC power supply(BC-27) . Before turning the receiver ON be sure to plug it into an active 110-220VAC wall socket and into the rear of the IRR-30 (12). DO NOT USE any power supply except the our standard.

IRR-15 Receiver Set up

I. Receiver Front Panel:

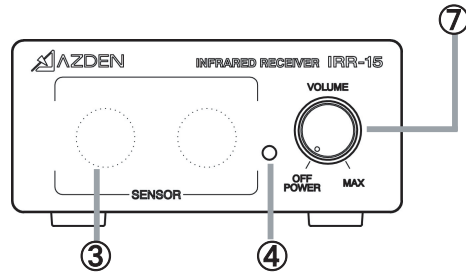

1. Power/Volume control - turn the receiver On and Off, adjust the mic output gain.
2. Power LED - Indicate the power state of the receiver. (RED: Power on, Green: Receiving signal)
3. Receiving Sensor - internal receiving infrared sensors.

II. Receiver Rear Panel:

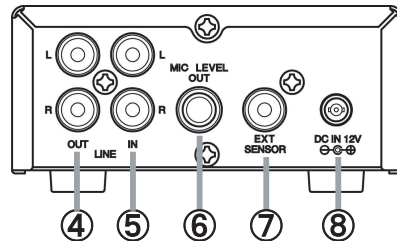

4. Mic/Line output - output both mic and line input signal. connects to audio amplifier/mixer aux input.
5. Line input - input line level signal in here
6. Mic output - connects the receiver to audio amplifier/mixer mic input.
7. External sensor input - Plugging an external sensor in here.
8. Plug in AC adapter (BC-27) to power receiver. Don't use other one beside of our recommending.

IRB-10c Transmitter

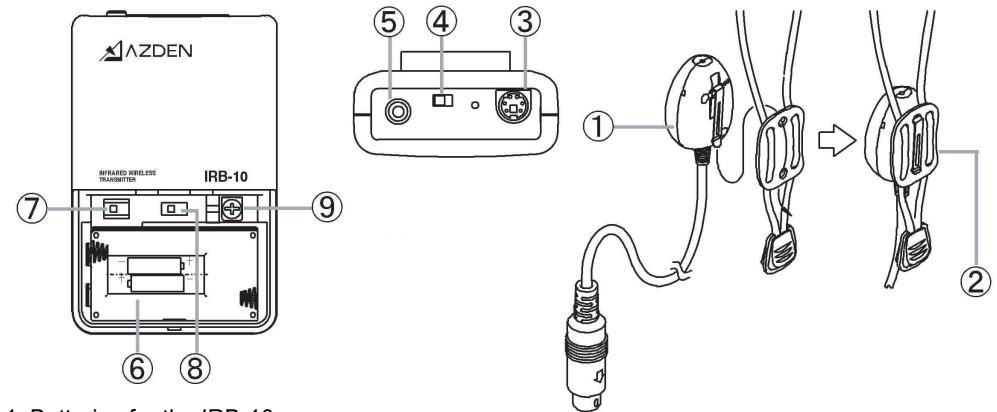

1. Batteries for the IRB-10c:

The IRB-10c uses two "AA" batteries for power. They are placed in the battery compartment. After sliding the battery case door off, carefully place FRESH batteries in the compartment in the directions shown on the sticker. **OBSERVE PROPER POLARITY!** The IRB-10c can use either Alkaline or Ni-MH batteries. In the case of rechargeable batteries, be sure that they are FULLY CHARGED before use. Battery life depends on the type of battery used.

2. Frequency Selection:

The IRB-10c can be set to transmit on either one of two preset frequencies. This is so that two different speakers can talk at the same time in the same room. While it does not matter which frequency is chosen for the body-pack, two transmitters cannot share the same frequency at the same time. To select the desired frequency (channel) slide the switch (8) as shown on the sticker on the back of the battery door.

3. Power Mode Selection:

The IRB-10c has two Power Modes - Lo and Hi. These modes can be selected via a switch (7) inside the battery compartment, and affect two areas related to performance- battery life and area coverage. If the body-pack is switched to the Hi position (7 - to the right) the range is set to maximum (approximately 144 square meter (1600 square feet)) while the battery life is reduced to approximately 10 hours with Alkaline batteries. If, on the other hand, the body-pack is switched to Lo the operating range is reduced to approximately 108 square meter (1200 square feet) and the battery life increases to approximately 15 hours with Alkaline batteries. Experimentation is the only way to know which position is best for your room. We suggest, however, that it always best to use the Lo position if possible as that provides the most economical use.

4. Adjusting MIC Gain:

The MIC gain (volume) is adjustable to compensate for various microphone element characteristics. The adjustment (9) is located in the battery compartment and can be adjusted using the provided tool. While speaking into your microphone, adjust the gain (more gain-clockwise rotation, less gain-counterclockwise rotation) until the desired volume level is achieved. Best results are normally achieved when the gain control on the IRB-10c body-pack and the volume control on the IRR-30 receiver (4 or 6) are both at their mid-points.